



*Next Meeting; Tuesday July 17th at 7.00 PM, Saturday Workshop is the following
Saturday, July 21st 2012 From 0900 to 1500 hrs*

July 2012

**Executive Committee
2011 / 2012**

President

Phil Tonks 9625 9202

Vice president

Ray Barrett 47393502

Secretary / Treasurer

Ian Griffiths 47313045

Floor Members

John Oakey 47396143

Daniel Clift 47392782

Philip Knight

Publicity Officer

Ray Barrett

Equipment Officer

John Oakey

**First Aid Officer &
Newsletter**

Daniel Clift

Catering Officer

Philip Knight

**Projects and
Demonstrations**

Phil Tonks

Presidents Report.

Ian and myself paid a visit to Val Rankine and were able to obtain permission to name our annual competition the 'John Rankine Memorial Trophy'. An invitation to attend our annual Christmas Party was extended, so she could present the trophy to the inaugural winner of the club challenge. Val is in good health, but she misses John very much.

Remember our visit to Anagote Timbers? Well, have you used any of the timber which you purchased? If so, then bring it along to the next 'show and tell' so we can all see what you have made.

Some eight members enjoyed the outing to Trend Timbers, Henry Bros, (*this was not planned*), and the Windsor Book Barn. A nice lunch was had at the Macquarie Arms Hotel, and then journeyed home.

Ask Doug Cox about the \$50.00 magnesium alloy 'Klic Klamp' acquired for ZERO dollars!!! the Club scored a sharpening angle tool, also at no cost – thank you Henry Bros.

Projects

Tuesday July 17th Doug Cox will teach us how to make hand made dovetail joints. This will be a hands on exercise, and yes, they can be made without Power Tools!

For this hands on, please bring along the following items;

- | | |
|---------------------------|----------------------------------|
| > A 2H pencil | > Mallet |
| > Sliding bevel | > Square |
| > Jap Pull saw | > Dovetail saw |
| > 12/15 bevel edge chisel | > 5 or 6 bevel edge chisel |
| > G Clamps/s | > Scribing knife / Stanley knife |

The club will supply any necessary timber.

Saturday July 21st Projects

Your own projects, Continuing table restoration, Mobile Library, Box making, (*Gifkins Jig*), Router made Trivets, (*for Australia day at Glenbrook next year.*)

Doug has offered to do a session on hand made Mortise and Tenon joints. (*Please advise your interest in this.*)

While every care is taken to ensure accuracy, the editor and publisher accepts no responsibility for any inaccuracies in articles or information contained in Fine Cut

**"If you don't
know where you are
going, any road will
get you there."**

Dates to remember

Bus trip to Clarence Timber mill. The bus trip is on Wednesday July 18th. And will pick up at the following points on the way.

- > On the western side of the lights, westbound, at Couglan Ave Blaxland, & the GWH.
- > Under the A W Bewley Bridge at Warrimoo.
- > Outside the Lawson Hotel
- > Outside the Wentworth Falls Hotel

Could you please ring/ Email me to advise which point you want to be picked up from, so as there is no confusion and we don't leave without you.

The bus will leave Penrith at 9.00am sharp, and will be at the pickup points at approximately 9.15am, 9.30am.9.45am and 10.00am respectively. This will allow us to get to Clarence at approx 11.00am.

The trip will cost \$15.00 per person. We will stop at the Imperial Hotel at Mt. Victoria for lunch after the Sawmill, then home. Finally, seats are filling fast, so Phone/Email Ian to book your seat.

*Working with Wood Show, **July 27th to the 29th** . Homebush. Make your own way here. (DAMN! I will be away!!)*

Bunnings BBQ on 15 September 2012

To be held at Bunnings (North) again - IG to request for volunteers.

DVD/Videos

A programme is being formulated.

Restored Chairs

These will be looked into at our next Saturday Workshop, to organise finishing them ASAP

Phil Tonks advised there is a joinery works at Milperra we may be able to look through as a Bus trip later in the year – he will follow this up.

Tool testing time again – Ray will organise the Electrician to attend.

Members will again be able to bring one personal tool to be tagged, however this must be a tool the Member would bring to the Club to be used at our Meetings.

The Blue Mountains Woodturning Club has asked us to give a box making demonstration of Gifkins Jigs & Bandsaws on the first Saturday in August 2012 at their place.
IG & PT are available.

Ray advised that a new set of arms (LH & RH arms) for the Triton saw bench is required, as the existing ones are faulty. (The measurement scales are no equal on both arms.) – Ian is to organise replacement.

Lost, stolen or strayed;

If any member knows the whereabouts of the feed tray from the Clubs Thicknesser, would they kindly advise the committee. This is an essential part of the equipment, and renders the unit unsafe to use. This tray as you are aware, is green in colour, and quite heavy.

Gov Grant;

The club committee is compiling a list of tools required to assist in our projects. Hopefully with a successful application we can procure same.

About the Club

The Club meets on the third Tuesday of the month at the Girl Guides Hall, at the end of Bunbinla Avenue Mount Riverview at 7:00 PM.

The Club also holds an all day Workshop on the Saturday immediately following the Tuesday night Meeting (not necessarily the third Saturday in the month), commencing 0900 am to 3.00pm

Visitors are invited to participate in up to three club meetings and/or activities.

After three visits if they are satisfied with the club's format and activities, they are expected to become full members of the club by paying the membership fees.

The meetings will start with a welcome to members and visitors. On Tuesday nights machines can only be used between 7.00PM and 9.00 PM. After 9.00 PM machines are unplugged and we all clean up and all equipment is put away.

Then 'Show and Tell', 'Questions and Answers', and our library is open
Supper is provided, and the Meeting is closed at 10.00pm.

On Saturdays machines can be used all day up to 3.15PM, then we all clean up, our equipment is put away, and our library is open.

"Show and Tell" and "Questions and Answers" will be immediately after lunch before we restart.
Morning and afternoon tea is provided, however BYO lunch and any other drinks etc.

Hall Cleanliness

The Girl Guides have expresses some concerns as to the cleanliness of the hall after we use it.

The Girl Guides have given us a list of what 'to do'. This list is a card, (laminated) and is in the 'purple' cupboard.

While every endeavour is taken to ensure we don't miss any item, we need to do a double check before we leave each day we use the hall.

Is there any thing that Members feel the Club is doing, not doing, or doing badly?

Please speak to Phil Tonks, or other Committee Members so we know, so we can attempt to rectify if we can

I think we have all spoken to this guy!

Mujibar was trying to get into Australia legally through Immigration.

The Immigration Officer said, "Mujibar, you have passed all the tests, except there is one more test. Unless you pass it you cannot enter Australia."

Mujibar said, "I am ready."

The officer said, "Make a sentence using the words Yellow, Pink and Green."

Mujibar thought for a few minutes and said, "Mister Officer, I am ready."

The Officer said, "Go ahead."

Mujibar said, "The telephone goes green, green, green, and I pink it up, and say, 'Yellow, this is Mujibar'

Mujibar now lives in a neighbourhood near you, and works at Optus on the Customer Service Desk.



Repairing Router Chipout

When routing a profile along the edge of a board, what can you do when the bit chips out a large piece of wood? If you're lucky and can find the broken-off chip, you can glue it back in place. But more often than not, the chip has been splintered or sucked into your shop vacuum.

My solution is like the trick an old greenskeeper uses on a nasty divot. First the "bad" section is actually enlarged out to the undamaged area. Then the area can be patched with a new piece to fit the hole.



Here are three easy steps for making this same kind of repair on a bad case of chipout.

1 Using a straight bit in the router table, rout a stopped rabbet along the damaged edge.

This will remove the chipout and create a straight edge for accepting a filler strip

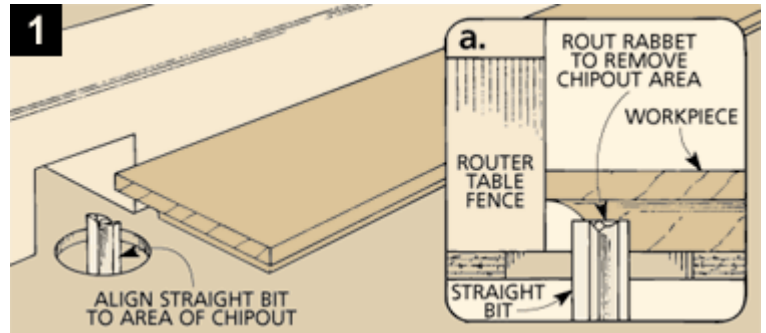

2. Cut an oversize filler strip to fit into the rabbet. Round one end to match the curve of the rabbet (where the bit stopped).

Then glue this filler strip in place and sand or plane the top surface flush.

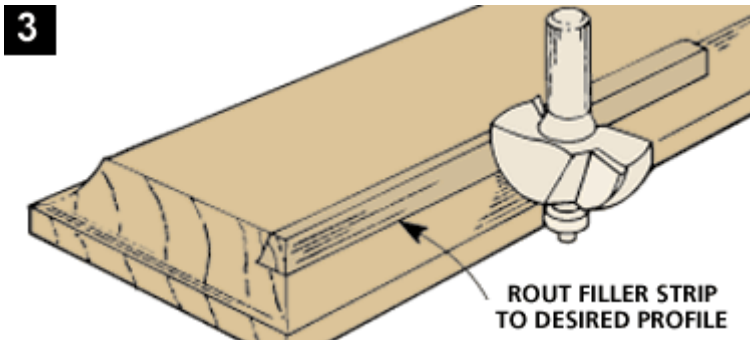
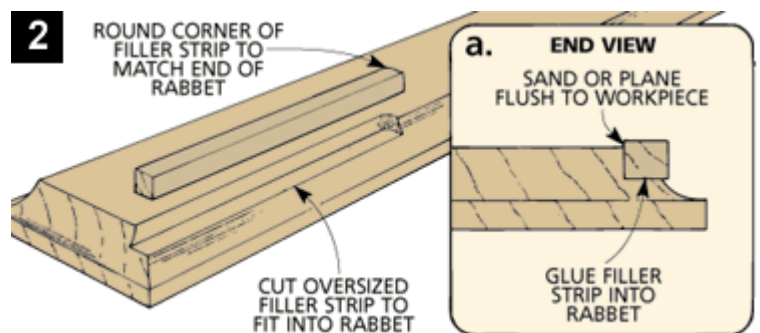

3. Now the original profile can be routed in the filler strip. (Hopefully without chipout this time.)

If you use a filler strip that matches the colour and grain pattern of the damaged wood, the repair will be practically invisible.

This article may be of some interest to members, although there are ways to minimize 'chipout' that may vary from those shown. (ed)

(From www.Woodsmithtips.com)